

Esco Ascent™ Opti Titramax  
Model SPT

## Ascent™ Opti Titramax

### Introduction

Titration analysis is a common laboratory method done to quantitatively identify the unknown concentration of a specific analyte. During this analysis, operators are often exposed to chemical fumes, vapors, and odor.

As an advocate of safety, Esco introduces the Ascent™ Opti Titramax, a specialized ductless fume hood designed to enclose titration devices such as burettes and auto-titrators while containing toxic vapour. Its ductless design offers customers full mobility and convenience as no complex installation system is required.

### Designed for Enhanced Usability and Efficiency

The Titramax is specifically designed to provide the operator with a high level of usability, comfort and visibility.

- Angled front sash ergonomically allows users to work further into the hood without strain, eliminating operator fatigue and increasing productivity.
- Transparent frameless acrylic front window and sides provide a high degree of visibility and operator comfort.
- Ergonomic oval-shaped apertures for hands in the front window allows for maximum reach within the work zone while providing the operator with extra protection from any possible chemical spillage.
- The sliding sash design provides easy access during loading and setting up of titration equipment inside the enclosure.
- Elongated height to accommodate a typical 50 ml burette, a 500 ml flask and a magnetic stirrer.
- Curved front edge minimizes airflow turbulence and improves user comfort.
- Electronic ballast for the fluorescent lighting provides zero-flicker with increased energy efficiency, reliability and service life with a lower heat output.
- Electrical pass-through on the back wall of the unit provide convenient access to power sources for devices such as magnetic stirrer/ hot plate.

### Enhanced Filtration System

Esco's Nanocarb™ activated carbon filters are constructed in order to ensure maximum filter efficiency, retention capacity and operator protection. Esco's research scientists and engineers, working in consultation with world-leading authorities on adsorption science, have developed the following set of unique technologies:

- Optimized retention capacity.
- Generously sized filters with more activated carbon by weight retain more chemicals and last longer.
- Quick-change out filter clamping mechanism allows filter replacements to be carried out with minimal tools;
- Diffusion technology to ensure even filter loading and better airflow uniformity.
- Optional sensing technology (VOC sensor) is available as an aid to predict filter saturation and warn the user to change the filters.

### Highest Quality Construction

- Industrial-grade main body constructed of electrogalvanized steel: with an abrasion resistant white after oven-baked powder-coated finish.
- Esco Isocide™ antimicrobial surface on all painted surfaces minimizes surface contamination.
- Permanently lubricated direct drive centrifugal fan(s); energy efficient external rotor motor type design reduces operating costs; extremely low noise and vibration levels due to proprietary construction and mounting technology.
- Industry exclusive baffle design for improved containment and efficient removal of chemical fumes from the work zone.

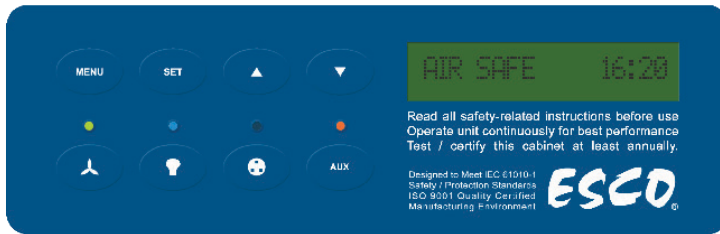

### Sentinel™ Silver Microprocessor Control, Alarm, Monitoring System

Esco's Sentinel™ microprocessor-based hood control systems supervises operation of all hood functions. The user-friendly microprocessor control system is fully configurable according to operator's requirements and comes equipped with a number of enhanced features to promote cabinet usability.

- Continuous monitoring of hood airflow is displayed on a bright, easy-to read LCD panel.

- Audible and visual alarms for low airflow and/or unsafe sash positions.
- An integrated, temperature-compensated, true airflow velocity sensor provides an accurate airflow reading despite room temperature fluctuation.
- An administrator controlled PIN (Personal Identification Number) can be set to restrict access to main menu.

### Options and Accessories

The Titramax is available with an optional Volatile Organic Compounds (VOC) sensor and a mobile base cabinet.

Guide to Models					
SPT -					
External Width	Code	Back Wall Construction	Code	Electrical Rating	Code
0.9 m (3 ft.)	3	EG Steel	A	220-240 VAC, 50 Hz	1
1.2 m (4 ft.)	4	Acrylic (transparent back wall)	B	115 VAC, 60 Hz	2
				220-240 VAC, 60 Hz	3

2

General Specifications, Ascent™ Opti Titramax					
Model	220-240 VAC, 50 Hz	SPT-3A1 2040301	SPT-3B1 2040304	SPT-4A1 2040307	SPT-4B1 2040310
	115 VAC, 60 Hz	SPT-3A2 2040302	SPT-3B2 2040305	SPT-4A2 2040308	SPT-4B2 2040311
	220-240 VAC, 60 Hz	SPT-3A3 2040303	SPT-3B3 2040306	SPT-4A3 2040309	SPT-4B3 2040312
Nominal Size	0.9 meters (3 ft)			1.2 meters (4 ft)	
External Dimensions (W x D x H)	840 x 700 x 1550 mm (33" x 27.6" x 61.0")			1145 x 700 x 1550 mm (45" x 27.6" x 61.0")	
Internal Dimensions (W x D x H)	790 x 600 x 1210 mm (31.1" x 23.6" x 47.6")			1095 x 600 x 1210 mm (66.7" x 23.6" x 47.6")	
Material Construction	Main Body	1.2 mm 18 gauge electro-galvanized steel with white oven-baked epoxy-polyester ISOCIDE™ antimicrobial powder coated finish			
	Side Walls	6 mm Acrylic Glass			
	Rear Wall	Powder coated E.G. Steel	Acrylic Glass	Powder coated E.G. Steel	Acrylic Glass
	Work Top	44 mm Thick Epoxy			
	Sash Material	Acrylic glass			
	Configuration	2-door sliding panels with ergonomic arm ports			
Filtration System	Nanocarb™ Filters (Type A-H)				
Fluorescent Light Intensity	>350 lux (> 28 foot candles) at work surface level				
Controller	Esco Sentinel™ Silver Microprocessor Controller				
Electrical Pass-Through	2				
Net Weight	145 kg (319.7 lbs)			165 kg (363.8 lbs)	
Shipping Weight	160 kg (352.7 lbs)			180 kg (396.8 lbs)	
Shipping Dimensions, Maximum (W x D x H)	1120 x 850 x 1820 mm (44.1" x 33.5" x 71.7")			1450 x 850 x 1820 mm (57.1" x 33.5" x 71.7")	

**Model SPT, Ascent™ Opti Titramax Ductless Fume Hood Engineering Drawing, 0.9 m to 1.2 m (3 ft to 4 ft width)**

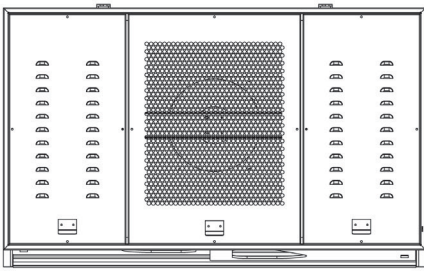

Top View, Electrical Panel

- 1. Sample Port
- 2. Filter ID Window
- 3. Sliding Sash
- 4. Pass-through ports for electrical or service connections
- 5. Sentinel™ Silver Microprocessor Control System
- 6. Ergonomic Arm Ports
- 7. Sash Handle
- 8. Fan
- 9. Nanocarb™ Filter
- 10. Baffle
- 11. Epoxy Worktop

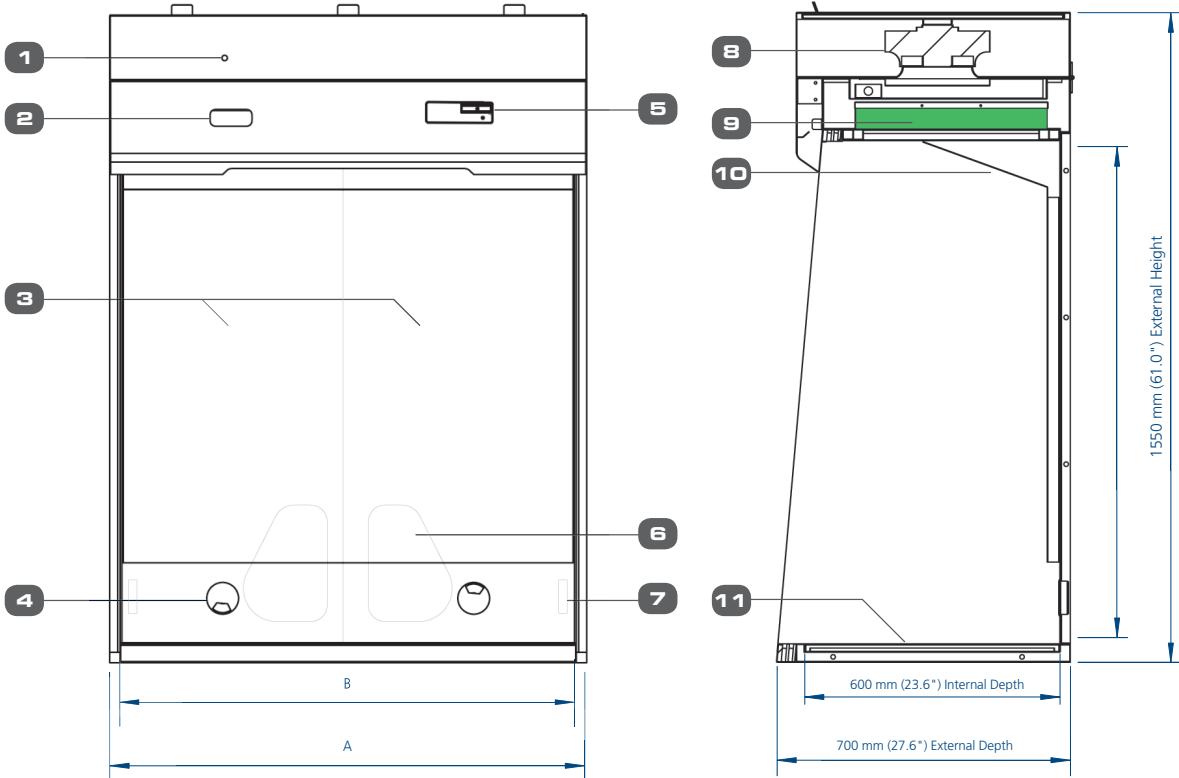

Model	A (External Width)	B (Internal Width)
SPT-3	840 mm (33")	790 mm (31.1")
SPT-4	1145 mm (45")	1095 mm (43.1")

**Model MBT, Mobile Base cabinet for SPT 0.9 m to 1.2 m (3 ft to 4 ft width)**

- 1. Hole for cabinet mouting
- 2. Shelf Tray
- 3. 5mm side perspex acrylic
- 4. Castor wheels

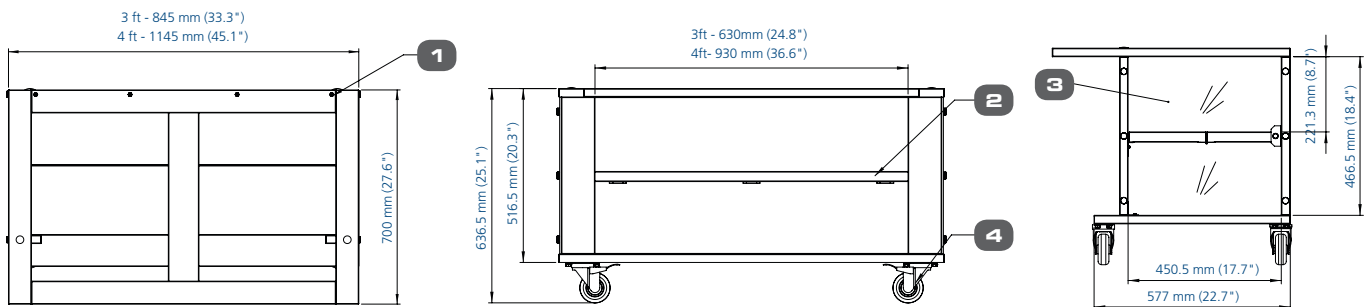

# ESCO LIFESCIENCES GROUP

42 LOCATIONS IN 21 COUNTRIES ALL OVER THE WORLD



- Global Offices
- Joint Ventures
- Licensee
- Distributors
- Factories
- R&D Centers
- Regional Distribution Centers

Join us on Social Media and Download our Apps!



Filtra Check App  
The World's First Chemical  
Evaluation App



Esco Social Media  
and Apps

# ESCO

LIFESCIENCES GROUP

Esco Micro Pte. Ltd. • 21 Changi South Street 1 • Singapore 486 777  
Tel +65 6542 0833 • Fax +65 6542 6920 • mail@escolifesciences.com  
www.escolifesciences.com

Esco Technologies, Inc. • 903 Sheehy Drive, Suite F, Horsham, PA 19044, USA  
Tel: +1 215-441-9661 • Fax 484-698-7757  
eti.admin@escolifesciences.com

Esco Lifesciences Group Offices: Bangladesh | China | Denmark | Germany | Hong Kong | India | Indonesia | Italy | Japan | Lithuania  
| Malaysia | Myanmar | Philippines | Russia | Singapore | South Africa | South Korea | Taiwan | Thailand | UAE | UK | USA | Vietnam